

PRODUCT FEATURES

Handle :	None Provided
Hinge :	16 Gauge Continuous, Welded To Door & Riveted To Frame
Bottom :	16 Gauge With Reinforcing Channels

PRODUCT INFORMATION

Material :	Mild Cold Rolled Commercial Quality Steel
Finish :	Baked Pure TGIC Powder Coat
Construction :	Welded One-Piece Structure
Door :	Open Front
Door Stiffener/Reinforcement :	None Provided
Door Frame :	16 Gauge
Door Ventilation :	Open Front
Door Latching :	None Provided
Top :	16 Gauge
Side :	16 Gauge
Back :	18 Gauge
Shelf :	16 Gauge
Interior Equipment :	(1) DBL Prong Ceiling Hook And (2) Hat Shelves Per Opening
Number Plate :	Polished Aluminum Plate
Assembly :	All-Welded

ACCESSORY INFORMATION

Slope Top or Hood :	None Provided
Lock :	None Provided
Legs :	None Provided
Base :	8" High CMU Base By Other
Recess Trim :	None Provided

Comments:
Color :

JOB INFORMATION

Locker Area :	Classrooms - See Plans	Alternate 1 - See Plans	Alternate 2 - See Plans
Frame/Openings :	556/556	56/56	56/56

Product Line : All-Welded SGL Tier Locker

Size : 15x16x48"

Original :	
Revised :	
Drawn By :	
Reviewed By :	
Page : 2 of 27	

**All-Welded Series
Single Tier Locker
15 x 16 x 48"**

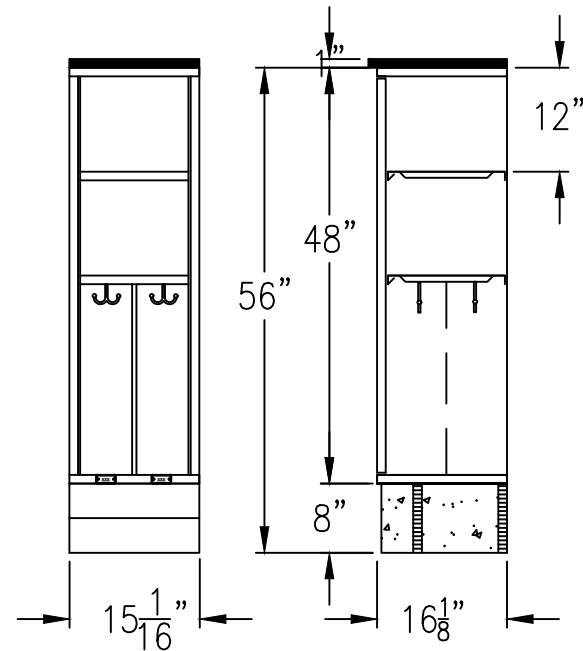

Tolerances in Manufacturing Understood: Fractions $\pm \frac{1}{16}$ ", Decimals $\pm .02$, Degrees $\pm 20^\circ$

NOTICE: All Rights Reserved, ©2023. These Drawings Of Products Described Are Subject To All Patents And Copyrights Held By Lockers Manufacturing.

PLEASE BE ADVISED:
Shop Drawings Are To Ensure We Understand Your Request. Your Approval Of These Shop Drawings Overrides Any Other Specifications Or Documentation. Please Check And Approve As We Are Going To Manufacture Material As Shown On These Drawings.